

37 SERIES Marker Lamps



Part#	Description	EAN Code
37AM2P	Side Marker, Black Housing, Blister Pack	9335962011889
37RM2P	Rear Marker, Black Housing, Blister Pack	9335962011896
37WM2P	Front Marker, Black Housing, Blister Pack	9335962011902
37CAM2P	Side Marker, Chrome Housing, Blister Pack	9335962011926
37CRM2P	Rear Marker, Chrome Housing, Blister Pack	9335962011933
37CWM2P	Front Marker, Chrome Housing, Blister Pack	9335962011940

Voltage	12/24V
Dimensions	70 x 35 x 20mm
IP rating	IP67
Warranty	5 Years
Cable	100mm (2P harness connectors)
Current draw (13.8V / 28V)	0.03A / 0.02A

ECE approval	Function	Approval#
	Front Marker (R7)	A-E9-02.6918
	Side Marker (R91)	SM1-E9-00.1017
	Rear Marker (R7)	R1-E9-02.6917

Wiring colour codes	BROWN: Power [+] WHITE: Earth [-]
----------------------------	--------------------------------------

Mounting instructions

⚠ Installation to be undertaken by a competent professional

CLICK & STICK EASY MOUNTING SYSTEM

Ensure mounting surface is flat, clean and dry prior to installation.

1. Drill 2 x 6mm holes for the two plugs
2. Drill a minimum 8mm hole for the wire
3. Peel off the paper protector for the 3M™ tape
4. Push lamp firmly into holes
5. The lamp is held in place by the plug serrations and the 3M™ tape

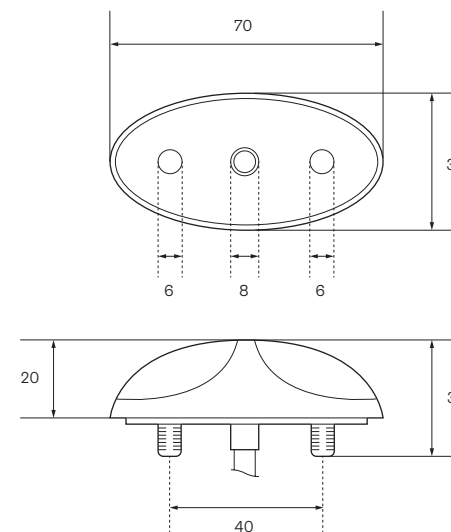
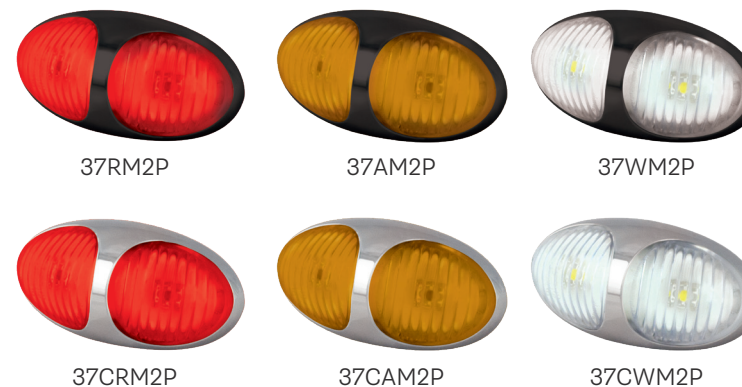

37 SERIES

Front/Rear Marker Lamps



Part#	Description	EAN Code
37RWM	Front/Rear Marker, Black Housing, Blister Pack	9335962019632
37CRWM	Front/Rear Marker, Black Housing, Blister Pack	9335962019625
37RWMBKT	Black Pendant Mounting Bracket, Bulk Pack	9335962019649

Voltage	12/24V
Dimensions	70 x 35 x 20mm
IP rating	IP67
Warranty	5 Years
Cable	400mm (stripped-end)
Current draw (13.8V / 28V)	13.8V: 0.04A / 28V: 0.04A

ECE approval	Function	Approval#
	Front Marker (R7)	AM-E9-02.11984
	Rear Marker (R7)	RM1-E9-02.11983

Wiring colour codes	BROWN: Power [+] WHITE: Earth [-]
----------------------------	--------------------------------------

Mounting instructions

⚠ Installation to be undertaken by a competent professional

CLICK & STICK EASY MOUNTING SYSTEM

Ensure mounting surface is flat, clean and dry prior to installation.

1. Drill a 10mm hole for the cable and plug
2. Peel off paper protector for the 3M™ tape
3. Push lamp firmly into hole
4. The lamp is held in place by the plug serrations and the 3M™ tape



37RWM

37CRWM

